

JAXA Solar-C Mission

Taro Sakao¹ and Saku Tsuneta²

JAXA Solar-C WG

(1: ISAS/JAXA, 2: NAOJ)

ESA-JAXA bilateral meeting
September 17, 2010, ISAS/JAXA

JAXA Solar Physics missions

With NASA and ESA participation

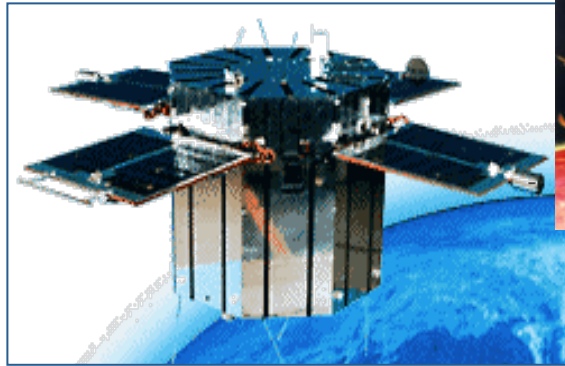

Hinotori/ASTRO-A
(1981–1982) ISAS

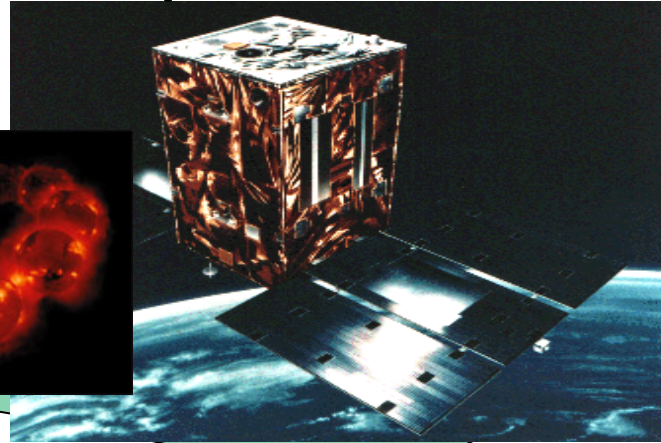
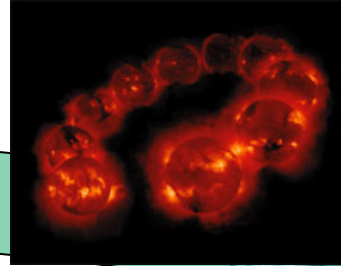
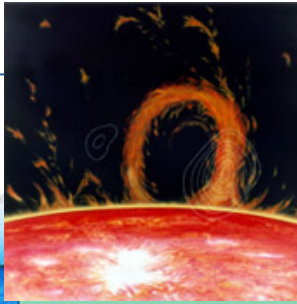

Yohkoh/SOLAR-A
(1991–2001) ISAS, NASA, PPRAC

Hinode/SOLAR-B (2006–)
JAXA, NASA, STFC, ESA

Solar-C
J-FY 2018

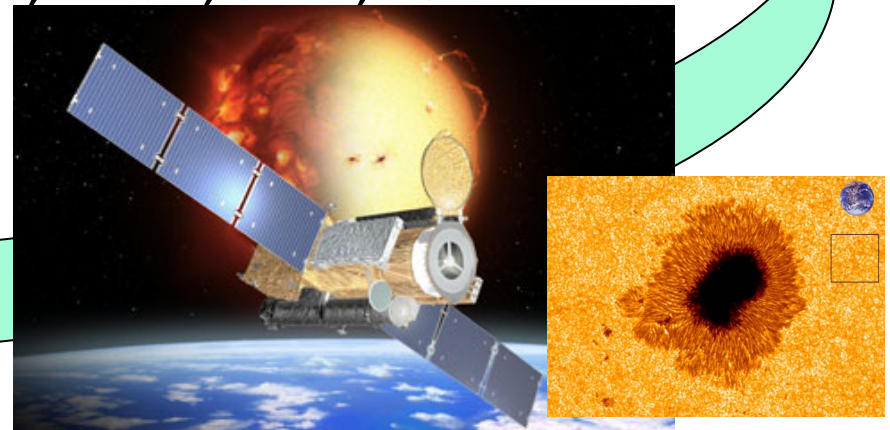

ESA and NASA contribution to *Hinode* data downlink supports

- In X-band downlink era (before 2008 April), >80% science data was downloaded at Svalbard, with ESA's great contribution to the downlink supports.
- After *Hinode* lost its X-band downlink capability, S-band backup downlink capability has been used.
 - In an effort to compensate for the reduced downlink rate, ESA, NASA, and JAXA have been continuously supporting an increase in the number of daily downlink passes.
 - Approximately 35-50 passes per day
 - ESA supports 9-17 passes at Svalbard and Troll.
 - NASA supports 8-12 passes at McMurdo and Wallops
 - JAXA supports 22-30 passes at USC, JAXA GN antennas and other commercial stations
- ISAS/JAXA and the *Hinode* international team appreciate this contribution and strongly encourage the continuation of the support.

Hinode Open data policy:

Acquired data is released immediately
1 refereed paper per 3.5 days all over the world

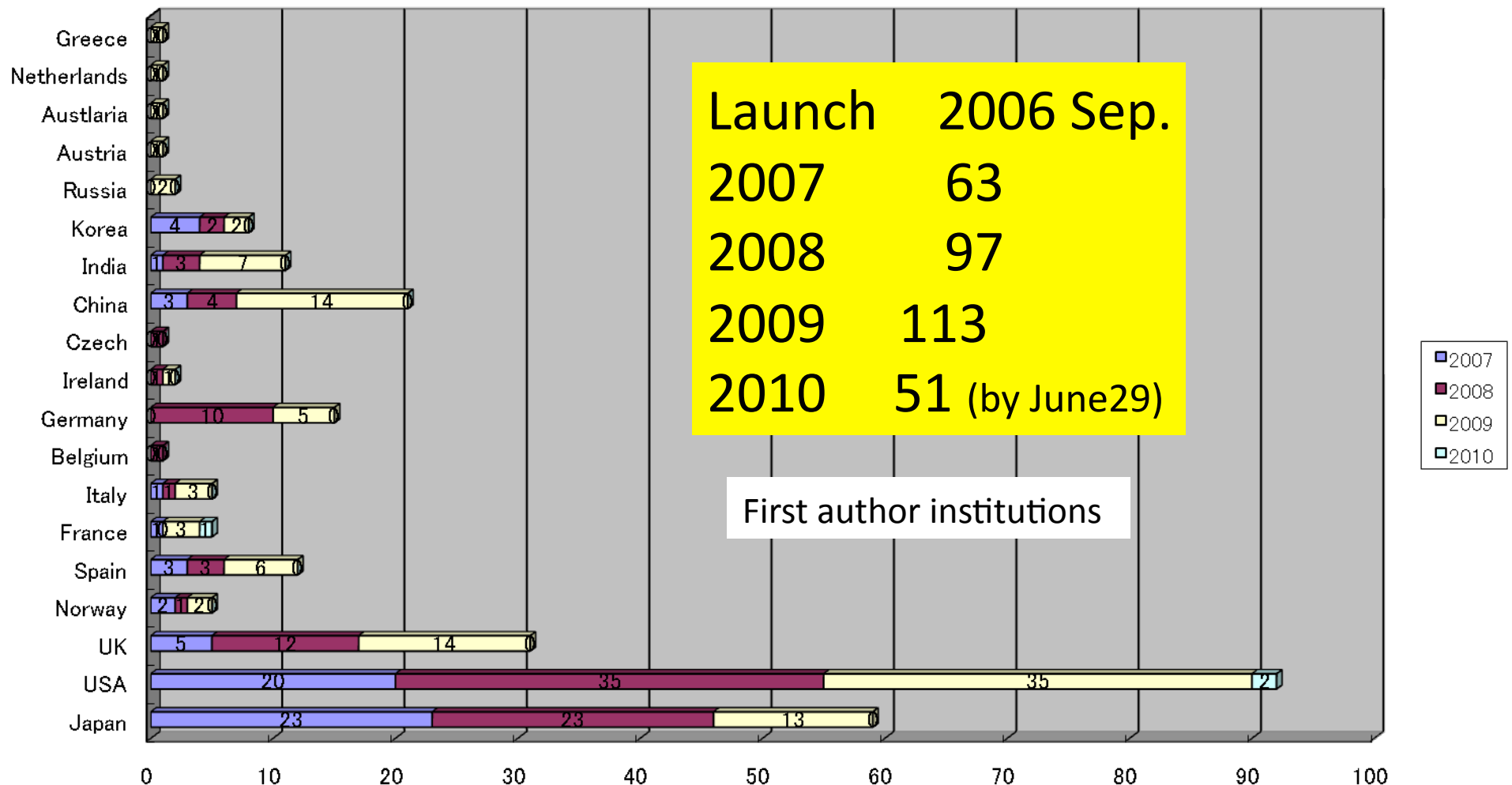

Outline

- Introduction to Solar-C, Plan-A and B, including candidate instruments.
- Recent & near-term Solar-C activities and milestones
- Possible areas of collaboration between NASA/ESA and JAXA

Two Solar-C Mission Concepts

- Plan A
Out-of-ecliptic helioseismic/magnetic observations of the polar regions to investigate internal rotation rate of the Sun, meridional flow, and magnetic properties of the polar region with EUV observations
- Plan B
High spatial resolution, high throughput, high cadence spectroscopic (polarimetric) observations seamlessly covering photosphere to corona to investigate magnetism of the Sun and its role in heating and dynamism of solar chromosphere and corona
- Provisional launch date: Japanese fiscal year 2018 (CY February 2019)
- Expects joint observations with highly complementary missions such as NASA SDO, NASA Solar Probe and ESA/NASA Solar Orbiter

Plan A: Out-of-ecliptic helioseismic/magnetic observations

- Polar region is unexplored important areas, and Plan A mission has significant discovery space.
- Plan A is an essentially helioseismic mission and is optimized accordingly
- Key Measurements:
 - Obtain internal rotation of the polar regions
 - Obtain sub-surface flow field of the polar regions including meridional circulation
 - Observe reversal of polar magnetic fields and reveal properties of polar fields
 - Increase our understanding on the solar dynamo process as a result of these helioseismic and magnetic observations
 - Reveal acceleration mechanism of fast wind with magnetic and coronal observations on polar regions

Solar-C Plan-A Payload

- Visible-light Doppler/Magnetic imager
 - Helioseismic/magnetic full-disk observations
- EUV/X-ray telescope
 - Coronal dynamics in polar regions
- EUV imaging spectrometer
 - Flow/wave structures in polar regions (plumes, solar wind)
 - Maybe combined with EUV/X-ray telescope
- Total irradiance monitor
 - Latitudinal distribution of surface irradiance
- Options
 - Heliospheric imager: CME imaging, solar wind/CIR shock structures
 - In-situ instruments

Near-Earth orbit using ISAS ion engine & Earth swing-by

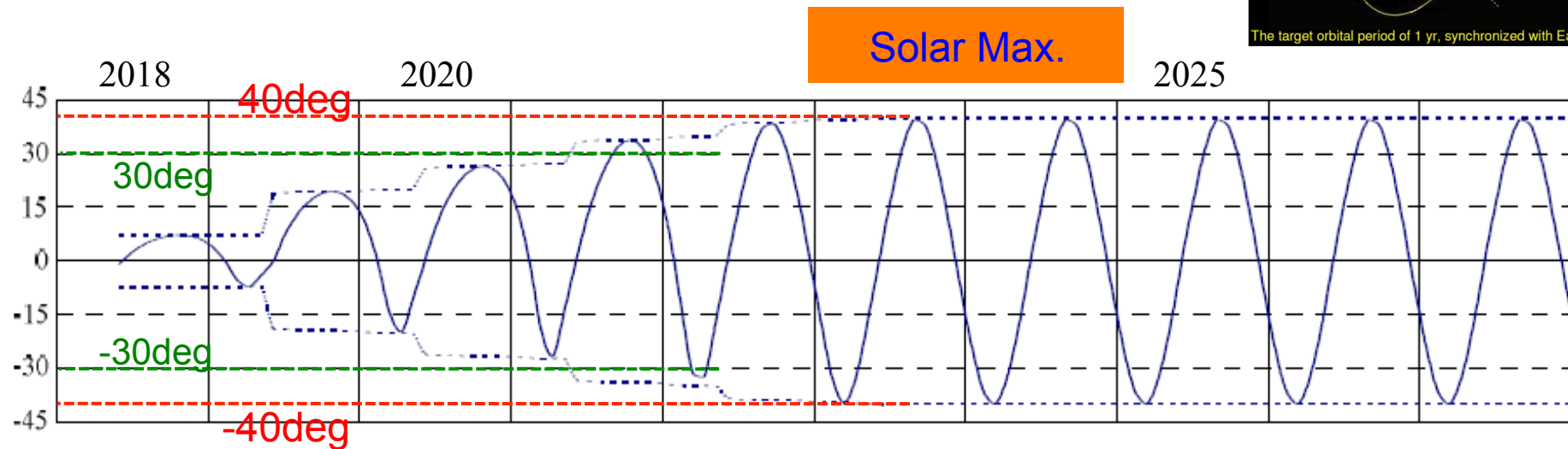
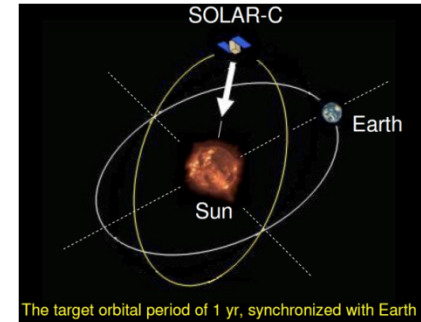

- 40° inclination from solar equatorial plane, essentially maintaining 1AU distance, synchronized with Earth
- ~ 3 yr to reach 30 degree and 5 year to reach 40 degree.
- Observations for North and south polar regions every half year even before reaching the observing point.
- Launch opportunity: every 0.5 year
- Orbit suitable for helioseismology in terms of observing duration for polar regions

Solar-C Plan-A Spacecraft

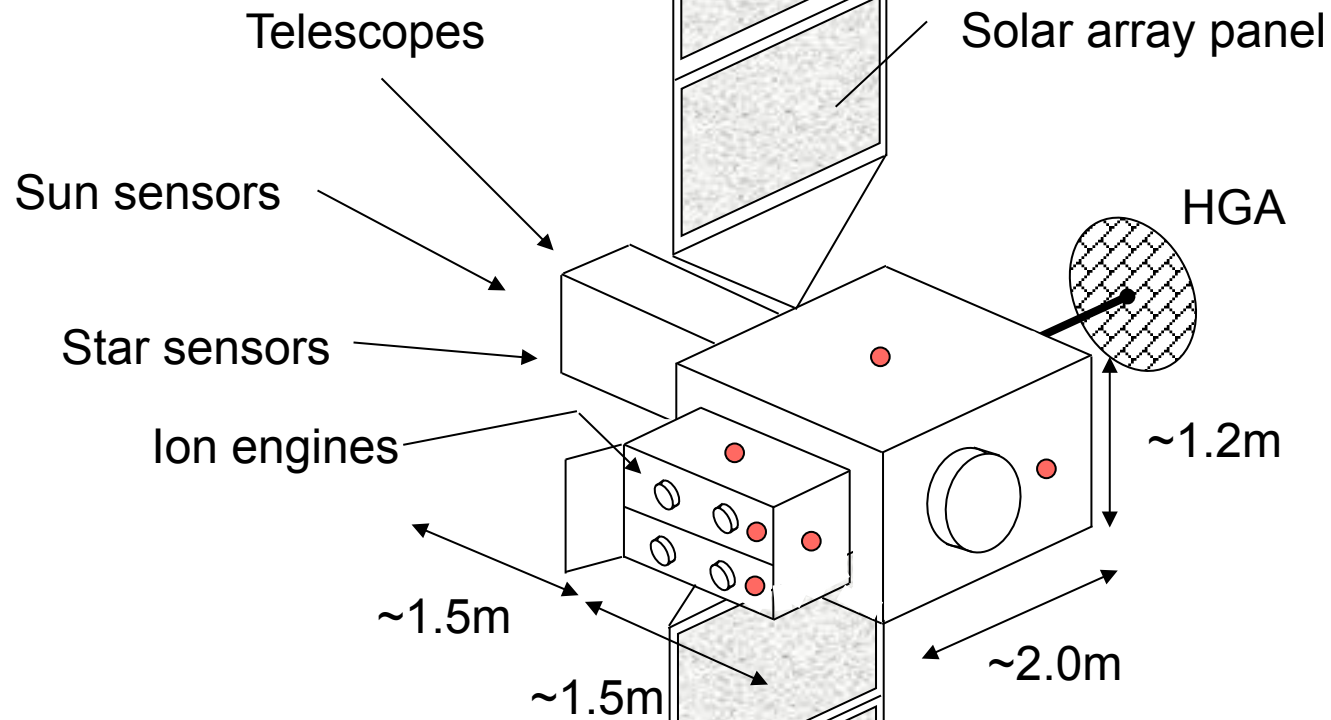

Maximum usage of Hayabusa technical heritage (ion engine, Interplanetary flight)

● Panels act as radiators.

Solar-C Plan A satellite weight, power and telemetry

- Weight ... 1.2 t (wet) total
 - Mission Payload ... 130 kg
 - S/C Bus (incl. ion engines) ... 698 kg
 - Thruster fuel ... 266 kg (For ion engines and chemical thrusters)
 - Margin ... 106 kg
- Power ... ~7 kW total
 - Ion engines ... ~5 kW
 - S/C Bus ... ~1 kW
 - Mission Payload + Margin ... ~1 kW

	Description	Note
Orbit Inclination	30 deg in 3 yrs (2021) 40 deg in 5 yrs (2023)	Assumes JFY 2018 launch.
Telemetry	300 kbps @ 0.5AU x 8hr/day ~ 100 kbps ave. [X-band Case] 1 Mbps @ 0.5AU x 8hr/day ~300 kbps ave. [Ka-band Case]	Assumes 8 hrs of downlink/day. No Ka band station in Japan

Plan B: High³ (spatial resolution, throughput, cadence) Imaging-Spectroscopic Observations

- Fine structures dictate the large-scale phenomena taking place in the Sun and heliosphere
 - Our guiding principle is that important physics is located in small scales
- Powerful combination of high resolution and spectro-polarimetric capabilities for seamless observation of the entire solar atmosphere
 - Detect chromospheric vector magnetic fields
 - Reveal ultimate driver of the dynamism and heating of chromosphere and corona
 - Reveal physical properties of waves, turbulence, and reconnection in different layers of solar atmosphere
 - Reveal acceleration mechanism of the solar wind

Solar-C Plan B payloads (1)

- UV-Visible-Near IR telescope
 - The aperture size under study is 1.5 meter in diameter, which can accumulate one order of magnitude larger number of photons in an exposure time than Hinode SOT.
 - Spectro-polarimetric and imaging measurements of magnetic field and dynamics with chromospheric spectral lines
 - He 1083nm and Ca II IR(854nm) with Zeeman + Hanle effect sensitivity
 - Mg II k/h (280nm) most suitable for dynamics.
 - Variety of spectral lines available for diagnosing the wide range of the lower atmosphere from photosphere to chromosphere.

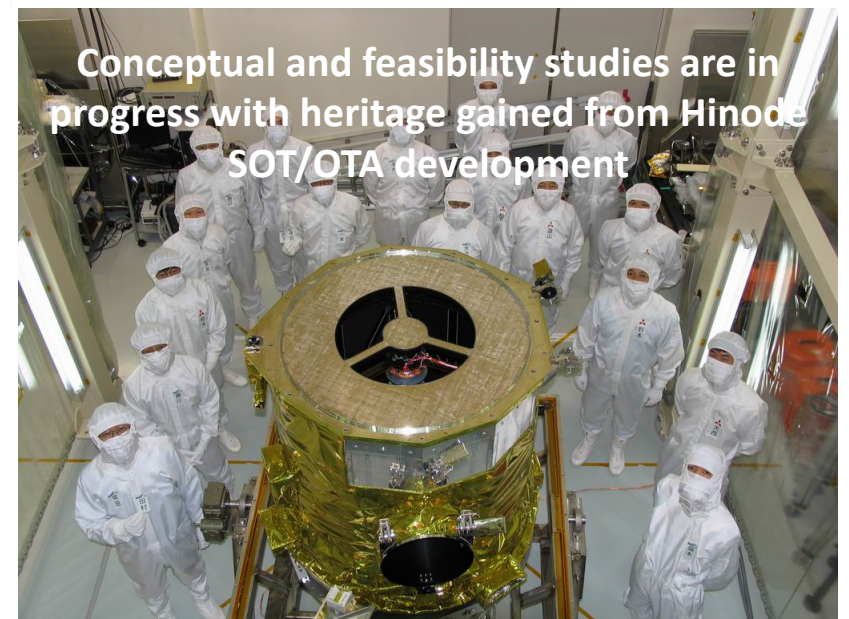
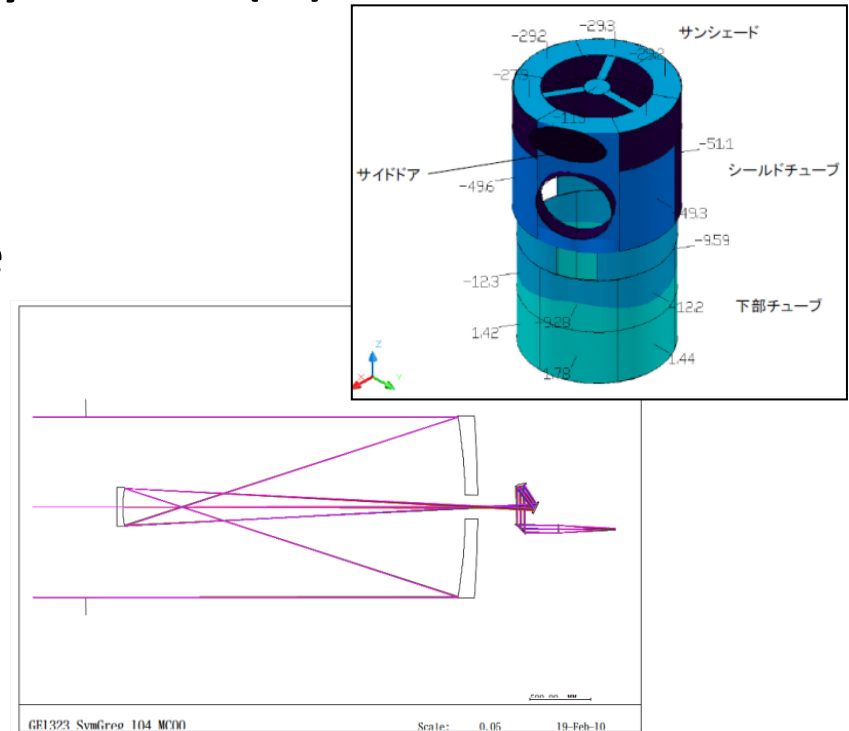

Solar-C Plan B payloads (2)

- UV/EUV high-throughput spectrometer

- High throughput to increase high temporal cadence
- High spatial resolution better than $\sim 0.5''$
- The entire coverage of plasma temperature from the chromosphere, transition region to the corona and flare.

Strawman spectrometer

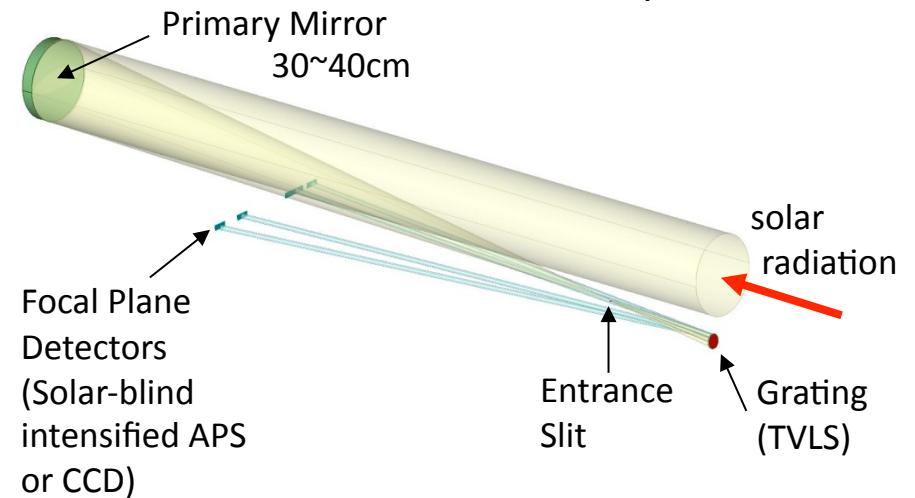

- Photon counting X-ray telescope

- Imaging emissions from $<1\text{MK}$ to 20MK coronal plasma
- Option 1) Photon counting capability for with grazing incidence telescope with 0.5 arcsec
- Option 2) Ultra-high spatial resolution ($\sim 0.1\text{ arcsec}$) for normal incidence telescope

Photon-counting X-ray telescope

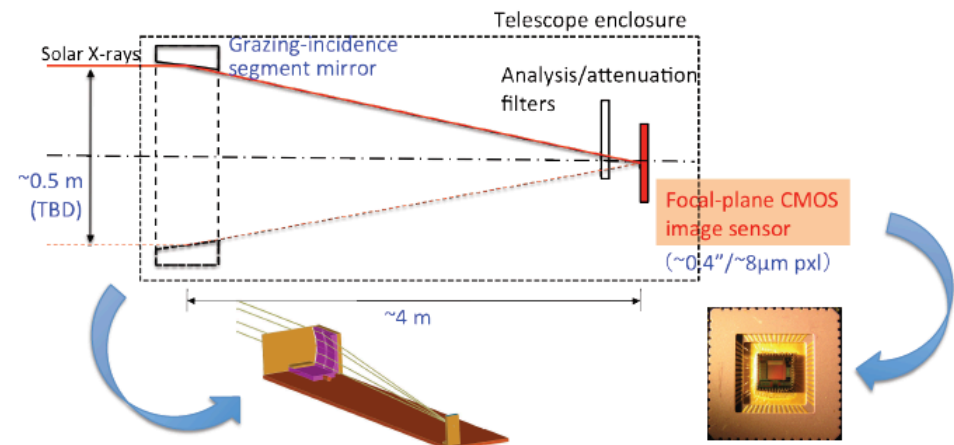

Solar-C Plan-B Spacecraft

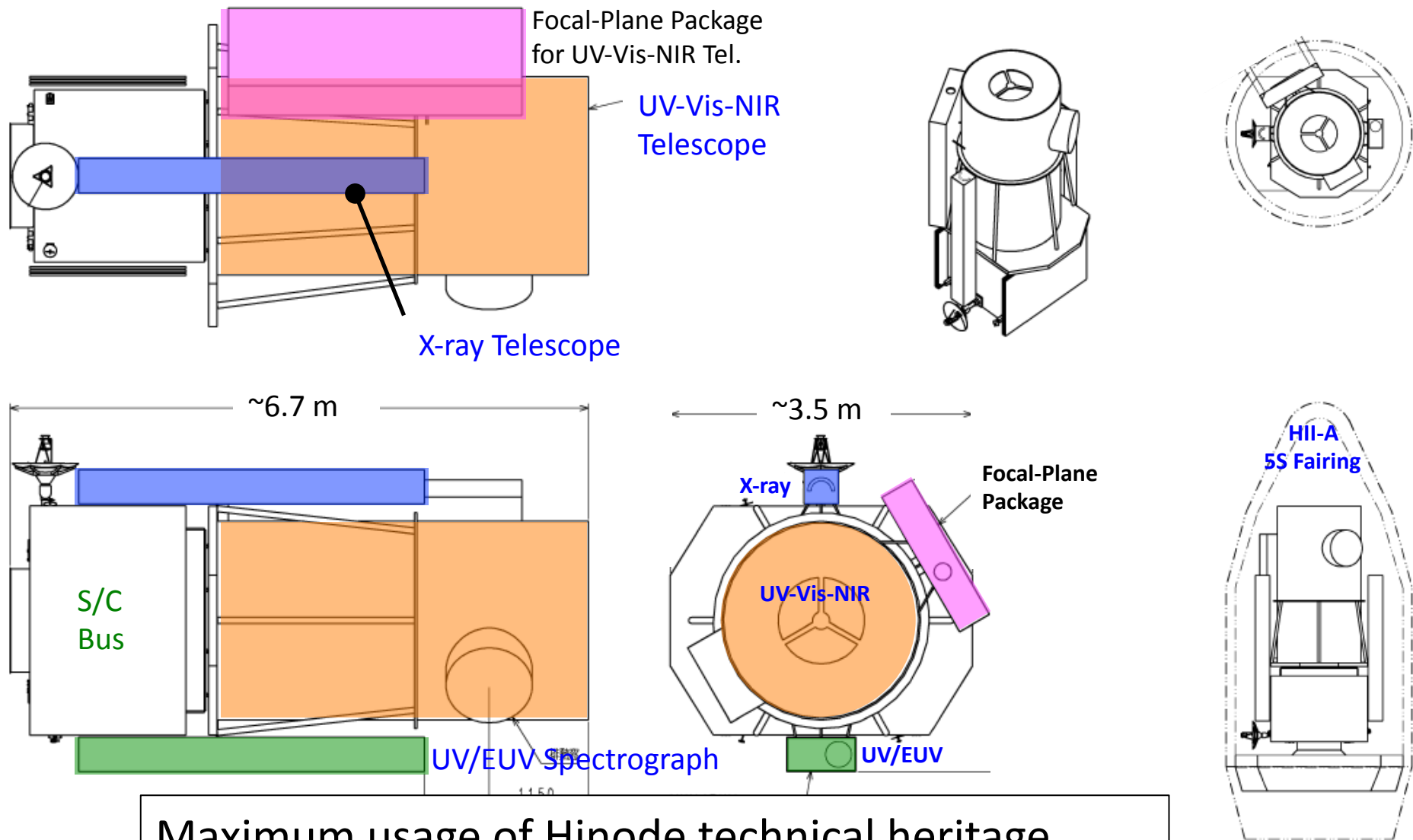

Maximum usage of Hinode technical heritage
(optical telescope assembly and S/C bus systems)

Solar-C Plan B Telemetry and Orbit

- High rate science telemetry is required to acquire spectroscopic/polarimetric data with high cadence and resolution. The current design target is the average data output of about 10Mbps from the onboard telescopes.
 - Data volume: 864Gbits in a day, c.f., Hinode ~36Gbits
- A conceptual study suggests an inclined geosynchronous orbit, similar to NASA SDO orbit, for the Plan B orbit.
- An X-band system (16Mbps, 16QAM) meets the requirement with the continuous link for >12 hours in each day.
- Another candidate is to use higher telemetry rate system available in Ka band. Note no heritage in Japanese science satellites to use Ka band for this kind of science data downlinks.

Recent International Activities

- Following the success of first International Solar-C Science Definition Meeting (Nov. 2008 at ISAS), international sub-WG were formed with participation of US and European scientists to produce technical reports.
- Second International Solar-C Science Definition Meeting (SCSDM2) held in Mar. 2010 at ISAS to review study results from the sub-WGs and to discuss Plan-A/B sciences.
- Inter-agency meeting held following SCSDM2 to discuss approach for international collaboration. Discussion particularly made for between JAXA-NASA.
- Development & assessment of Solar-C key technologies in progress with ISAS & JSPEC R&D funds in JAXA Solar-C WG.
- Communications between JAXA and NASA re Solar-C increased. Regarding ESA, Solar-C WG Chair (Prof. Tsuneta) visited ESA HQ in Apr. 2010 to discuss with Dr. Favata possible collaboration with ESA for Solar-C.
- There will be ESA-JAXA bilateral meeting and NASA-JAXA discipline meeting on September 17, 2010.

NASA-JAXA Joint Solar-C Science Assessment Committee (JSSAC)

- Agreed to establish in the Inter-Agency Meeting after SCSDM2 (March 2010).
- The primary purpose is assess how each of the proposed Solar-C plans are aligned with the US and NASA science goals for the next decade. In addition to the Decadal survey, the report is important for NASA HQ.
- Committee discussion initiated in September, with the first face-to-face Committee meeting on 10 Oct. in Palermo, Italy.
- JAXA-NASA discipline-level meeting at NASA HQ on Sep. 17 on JAXA-NASA Solar-C collaboration

Multi-purpose nature of Solar-C interim Report

- Fundamental documentation to tell solar physics and related science community and space agencies what Plan A and B missions would be.
- Plan A and B selection will be made based on the written Report (science), separate cost estimate, and community-wide preference
- The Report serves as the source of stimulation and imagination for any of the international partners to scientifically and technically improve the mission design
- The Report is the guiding document for alignment of the NASA-JAXA JSSAC activity with the JAXA Solar-C WG. As above, this activity is not just for the decadal survey.
- The Report will evolve into Mission Proposal Document that Solar-C WG plan to submit to JAXA upon AO call in autumn 2011.

ROM Cost-to-JAXA exercise

- Plan A S/C bus cost was estimated based on Hayabusa cost reality and Marco polo cost estimate.
- Plan B S/C bus cost was estimated by two major aerospace companies.
 - 1.5m telescope for SOT/OTA (Optical Telescope Assembly) including M1/M2 was estimated based on Hinode efforts by one company.
 - Spectro-polarimeter cost has not yet be estimated.
- Launch cost with JAXA H-II is known.
- Salary for scientists, in-house engineers/technicians and institutional overhead not included in the Japan accounting system.
- Cost target is JAXA ASTRO-H (X-ray astronomy mission) cost + alpha.

Possible Areas of Collaboration with NASA and ESA

- Areas of collaboration
 - Launcher
 - Ka and/or X band downlink station
 - Science instruments
- Business model with ESA
 - We prefer ESA's direct-involvement (rather than pure bilateral collaboration), following SPICA business model.

Activity Related to ESA's Cosmic Vision II

- As an activity evolved from the UV/EUV Spectrograph sub-WG, our European colleagues are planning to propose within ESA's CV II programme, the EUV/VUV Telescope (and its associated Spectrographs and cameras) as European contribution to Plan-B of Solar-C. MPI Solar System Research will be the PI institution.
- JAXA Solar-C WG greatly welcomes and supports the application to CV II while at the same time recognizing the following issues should be taken into account:
 - At the time of proposal submission on December 5 to the CV II panel, it is likely that the final decision on Plan-A/B is yet to be made within Japan and the United States. The application to CV II will not affect Solar-C WG's Plan-A/B selection.
 - Solar-C WG wants to have Solar-C launch in J-FY 2018 (CY March of 2019 the latest) while launch for CV II is in 2020 or later. This mismatch for CV II launch has to be worked out.

Calendar for Years 2009–2020

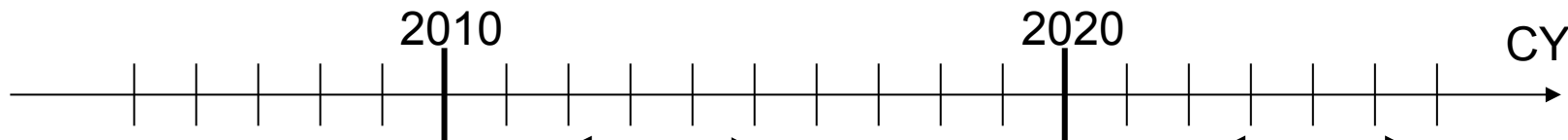

HINODE

2006 Sep. 23

- Phase 1** Initial analysis and discovery
- Phase 2** New development from solar max. observations
- Phase 3** New view with cycle-long observations

SOLAR-C

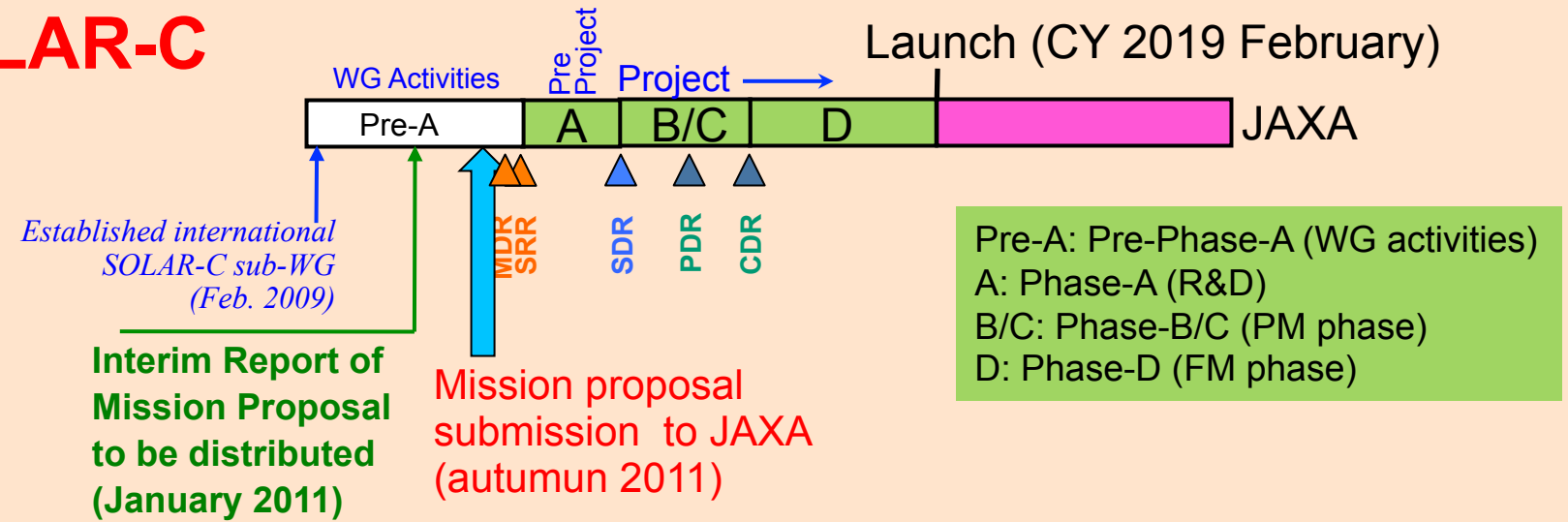

Sounding Rocket Experiment with NASA

CLASP

Kickoff (Nov. 2008)

Launch (summer 2014)

Summary

- Either plan would significantly enhance our understanding of the internal structure of the Sun and the magnetized plasma of the Sun.
- Solar-C observations have significant implications for both astrophysics and heliophysics.
- Fundamental study with Solar-C will enhance our prediction capability for societal impacts of space weather and climate.